



HOVERJACK®

Air Patient Lift

Recognised as the industry standard for safe patient lifting, the HoverJack® air patient lift allows caregivers to safely lift patients who have fallen without gathering a lift team. The HoverJack® inflates to lift patients from the floor to bed or stretcher height in a supine position, maximising patient comfort and minimising the risk of injury to the patient and their caregiver. Once the HoverJack® is inflated, the HoverMatt® air transfer mattress can be used with the same air supply unit for safe and easy lateral patient transfer to a bed or stretcher.



HoverJack Air Patient Lift Benefits:

- Minimise staff members needed to safely lift patients who have fallen
- Control height through individual chamber inflation
- Self-sealing inflation valves for ease of use
- Quick release deflation valves to lower patient if needed
- Teflon® bottom allows for easy movement across all surfaces
- Available in two widths with a weight capacity of 545kg to accommodate most patients



HoverJack® Air Patient Lift

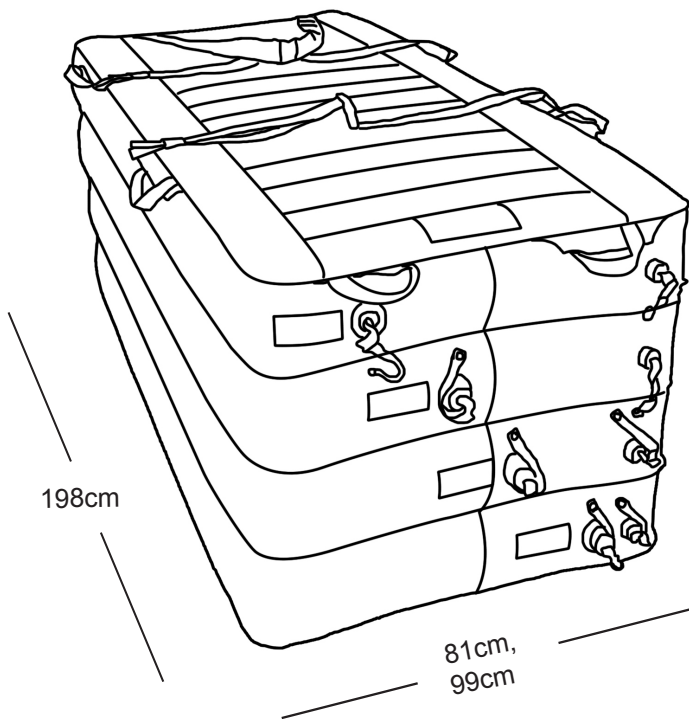

Product Specifications

Material Specs

Topside Material: Nylon Oxford

Underside Material:

Teflon® impregnated polyester

Latex Free

Available in 2 Sizes

81 cm W x 198cm L - MHHT-HJM-32

99cm W x 198cm L - MHHT-HJM-39

Inflation

- Four inflation chambers with self-sealing valves
- Four quick release deflation valves (red capped)

Compatible with HoverTech Air Supplies

MHHT-AIR2300 (Variable Speed)

For more information, contact your local HoverTech distributor, or Statina Healthcare International on 1300 791 404.



SHI221014

Distributed By:

Imported into Australia by:
Statina Healthcare International
6/30 Leighton Place, Hornsby NSW
sales@statinainternational.com
Ph: 1300 791 404